

## FRESHGROUND / FRESHGROUND XL (IRL/GB)

### 700.406.750-D

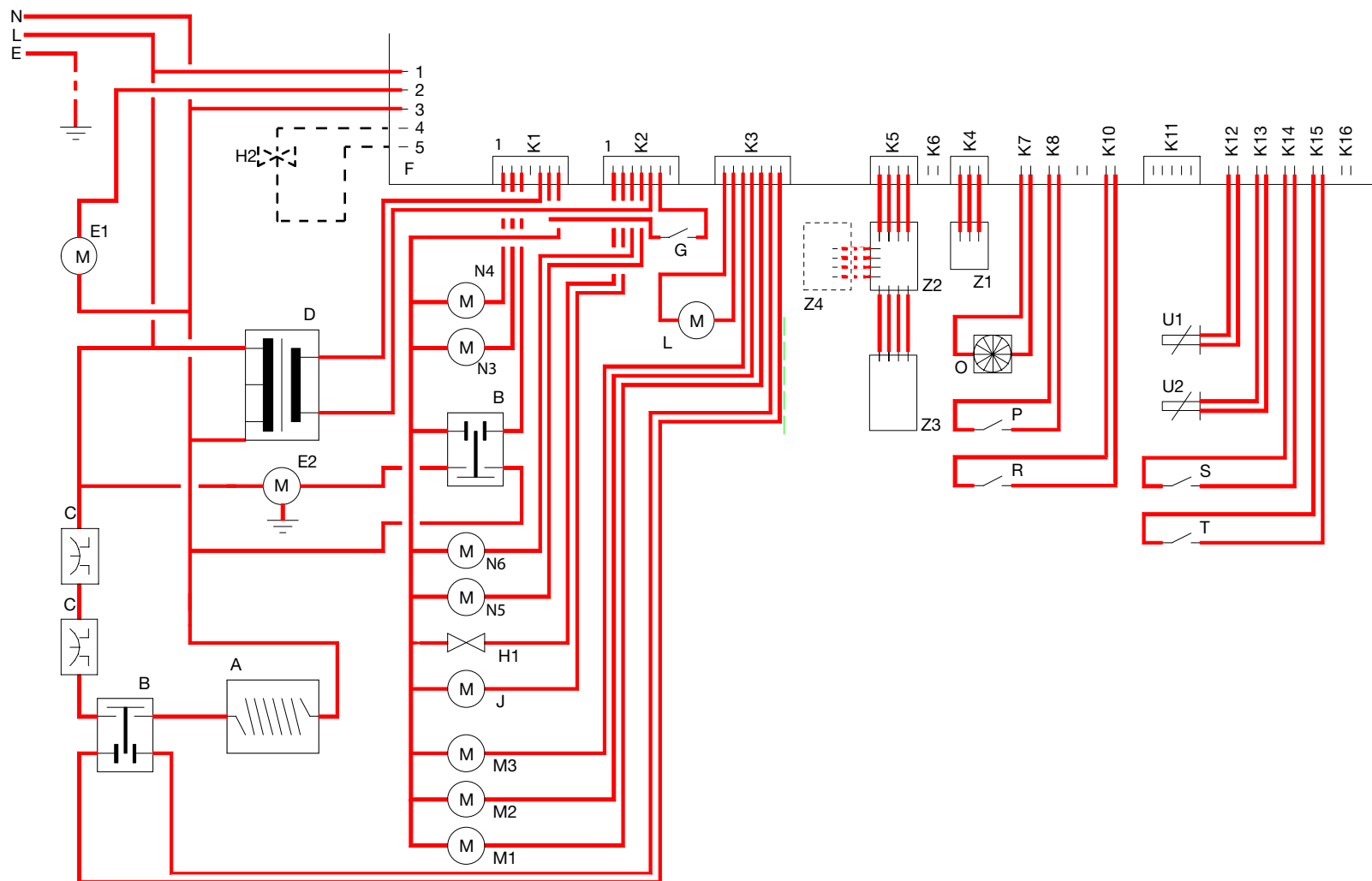

- A. Element
- B. Relay
- C. Temperature safety
- D. Transformer
- E1. Brewer motor
- E2. Grinder motor
- F. Mainboard
- G. Main switch
- H.1. Magnetic valve
- H.2. Magnetic valve kts
- J. Motor pump
- L. Motor water selector
- M1/3. Motor mixer
- N1/6. Motor canister
- O. Motor fan
- P. Floater
- R. Door switch
- S. Switch Brewer motor
- T. Switch paper
- U1/2. NTC resistor (temp.)
- Z1. Light sensor water selector
- Z2. Keyboard (light)
- Z3. Keyboard (button)
- Z4. Coin mechanism (option)